

## PA330A

PA330A 功率放大模块实现射频信号的功率放大输出。PA330A 输入电压 12V 时，接 Sihid RCB 或 RCA COFDM 调制板，输出发射功率最大可到 1W(+30dBm)。PA330A 支持工作频段 300MHz~360MHz。

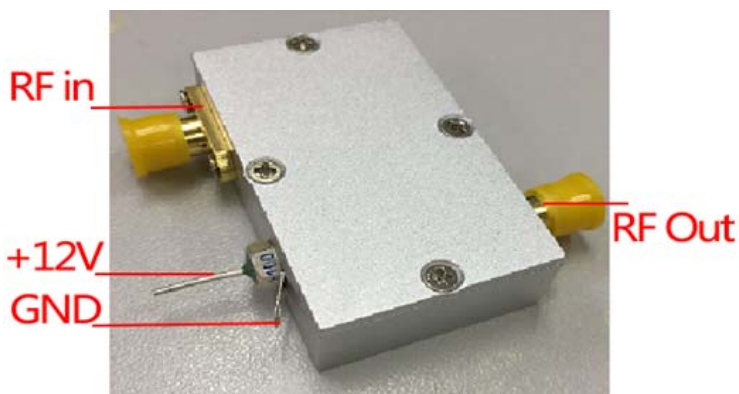
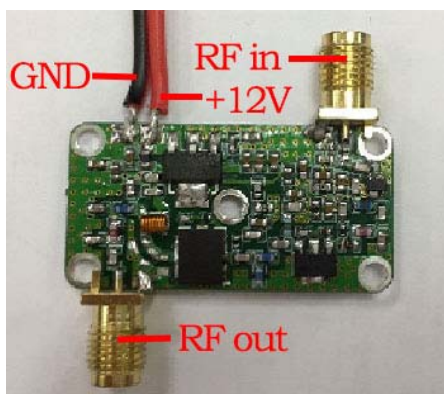

### PA330A 功能说明:

- 工作频段: 300MHz~360MHz
- Gain: 45dB
- Pout: +30dBm
- IP3: +49dBm
- Noise Figure: 4dB
- DC Power: 12V, 输出 1W(+30dBm)发射功率时, 功耗在 8W 左右
- RF 接口: SMA 外螺纹内针

Electrical Specifications @ +25°C,  $Z_s = Z_L = 50\Omega, V_{cc} = 12V$

Parameter	Unit	Minimum	Typical	Maximum
Frequency Range	MHz	300		360
Small Signal Gain	dB		45.0	
Gain Flatness	dB		+/-0.5	
Output Power Pout@Pin=-15dBm	dBm		+30	
IP3	dBm		+49	
ACPR(WCDMA PAR=9.9dB)	dBc		-40	
Reverse Isolation	dB		-45	
Noise Figure	dB		4	
Efficiency(Pout=+39dBm@470MHz)	%		13.8	
VSWR input			1.3:1	
output			2.0:1	
DC Power Supply	V	7.4	10	12
Supply Current (Quiescent)	mA		300	
板子尺寸(未计算接口器件伸出板边)	mm	35.1mm x 18.1mm x 0.6mm		

带铝合金腔体尺寸	mm	43.0mm x 26.0mm x 10.0mm
带铝合金腔体重量	g	29.4

Typical Performance @ +25°C

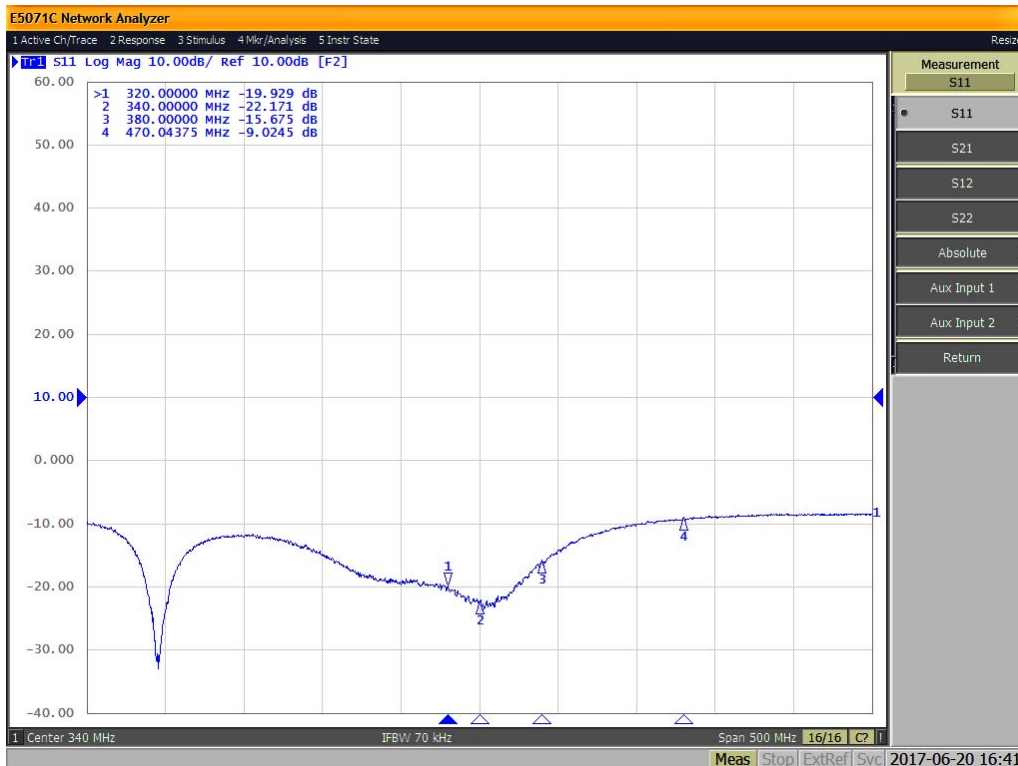

Input return loss (dB)

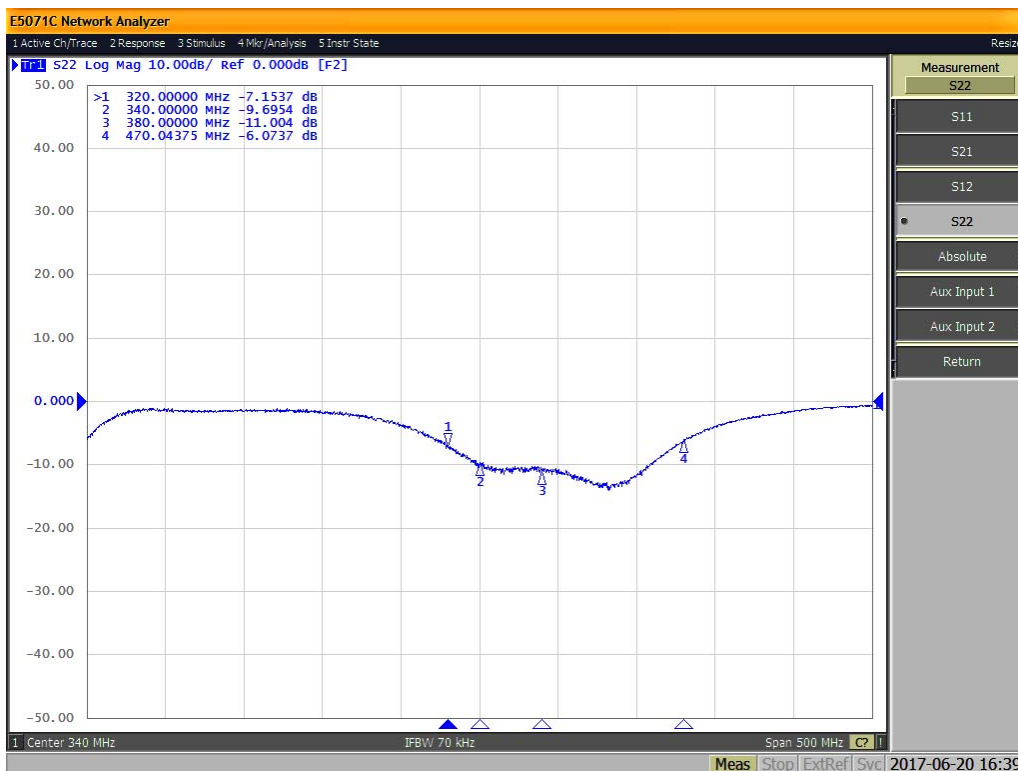

Output return loss (dB)

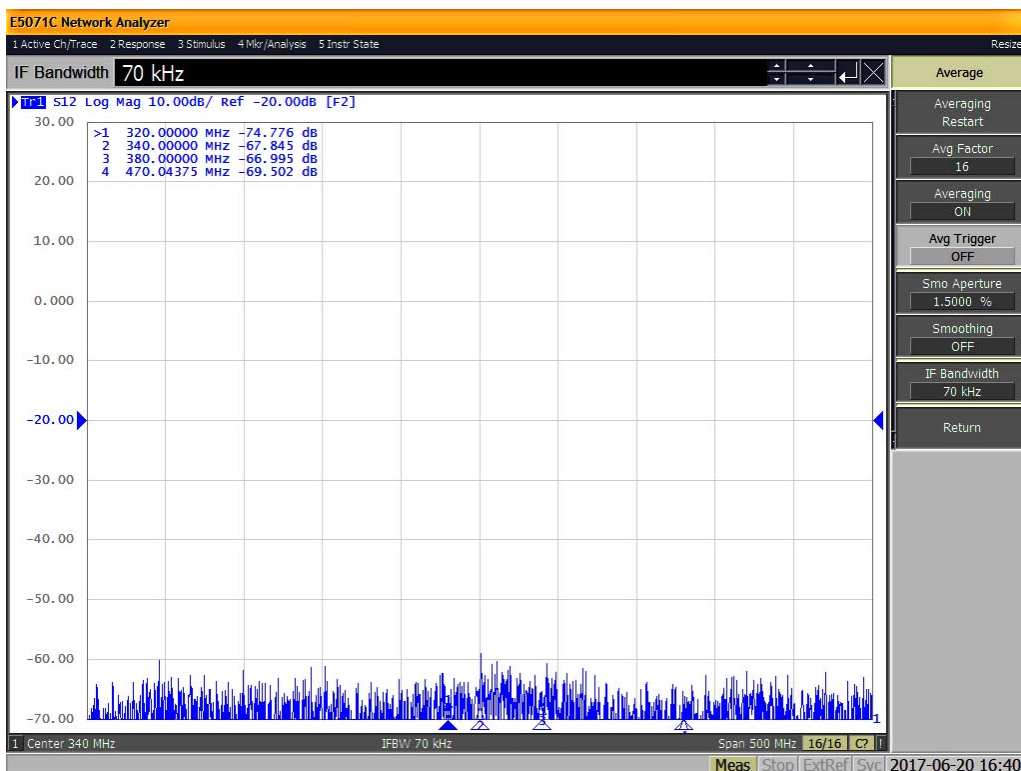

Isolation (dB)

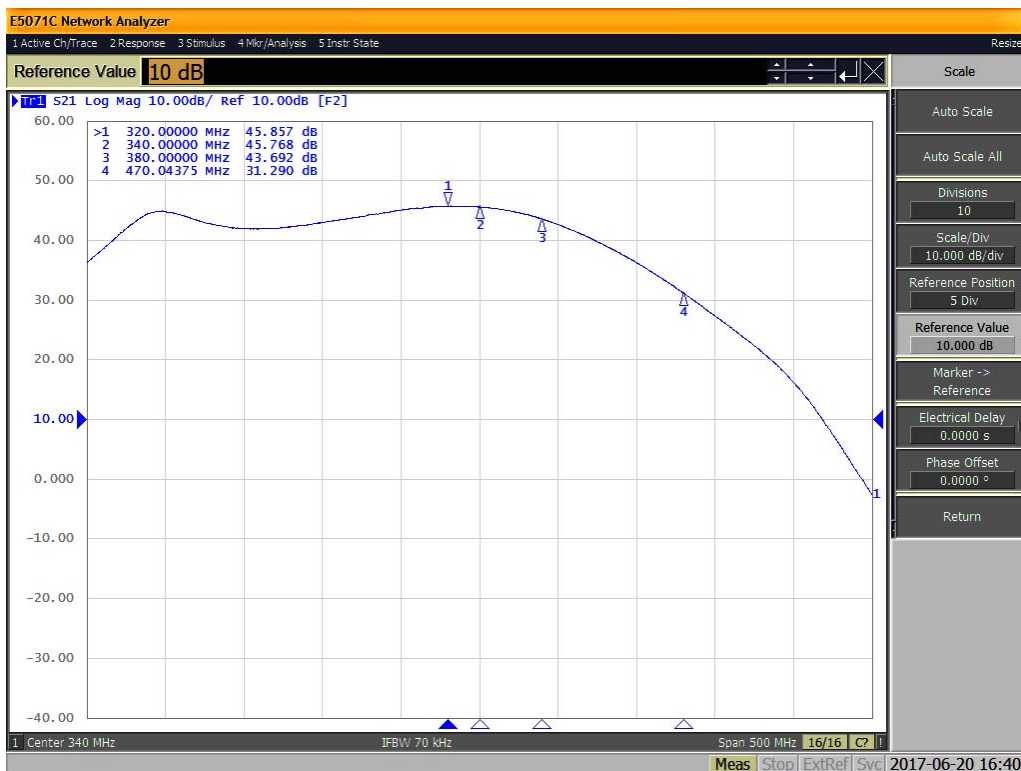

Gain (dB)

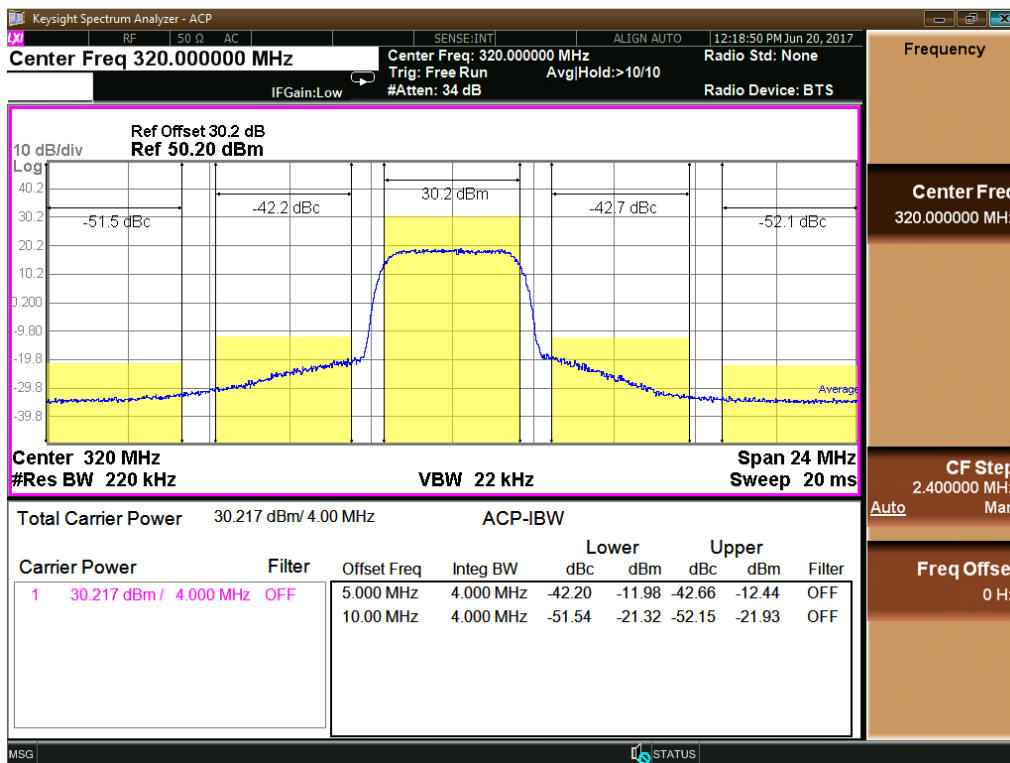

Pout @WCDMA 320MHz PAR=9.9dB

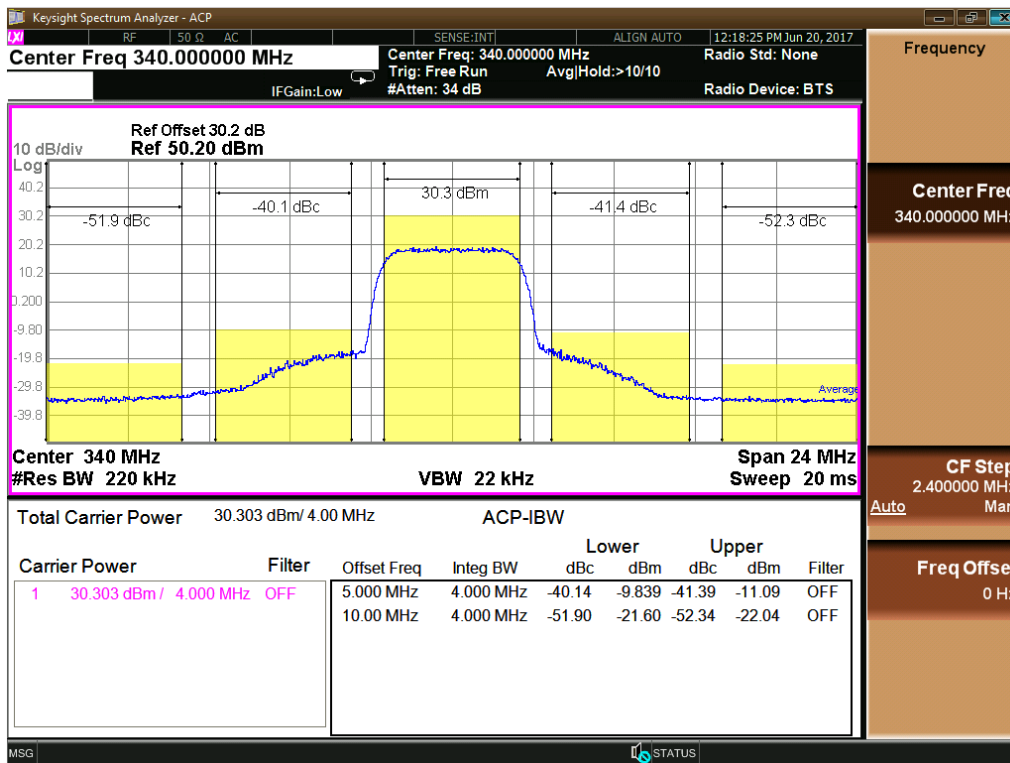

Pout @WCDMA 340MHz PAR=9.9dB

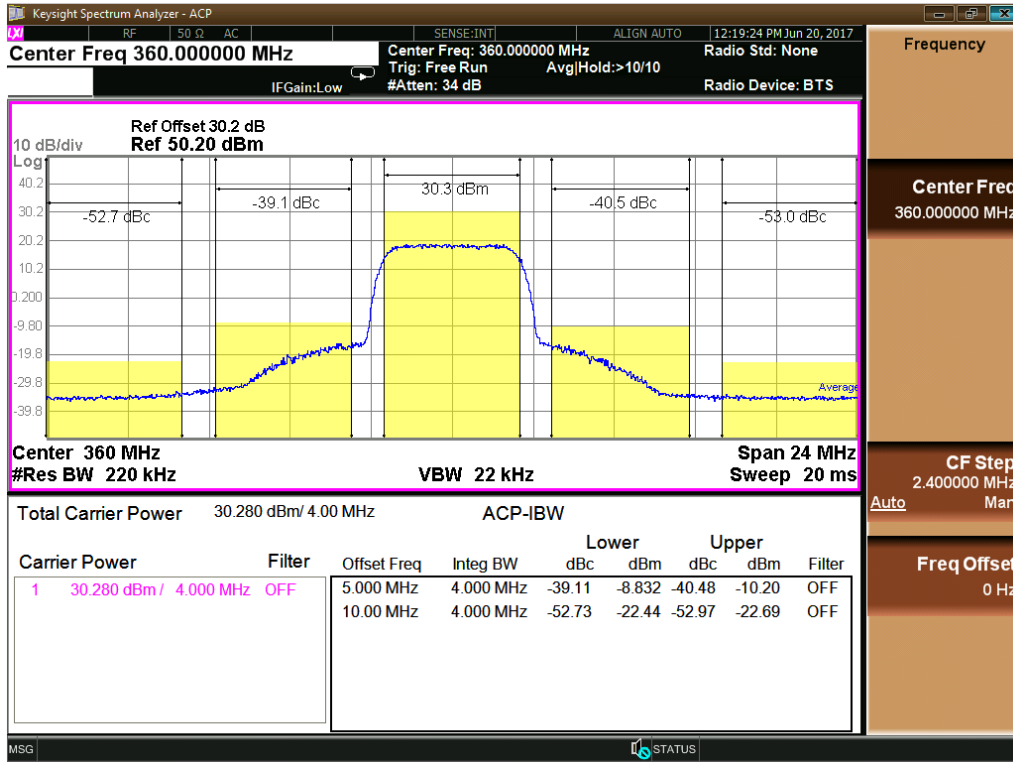

Pout @WCDMA 360MHz PAR=9.9dB

### Absolute Maximum Ratings

Parameter	Absolute Maximum
RF Input Power	-5 dBm
Supply Voltage	+14V
Operating Temperature	-40°C to +65°C
Storage Temperature	-55°C to +100°C

板子尺寸图:

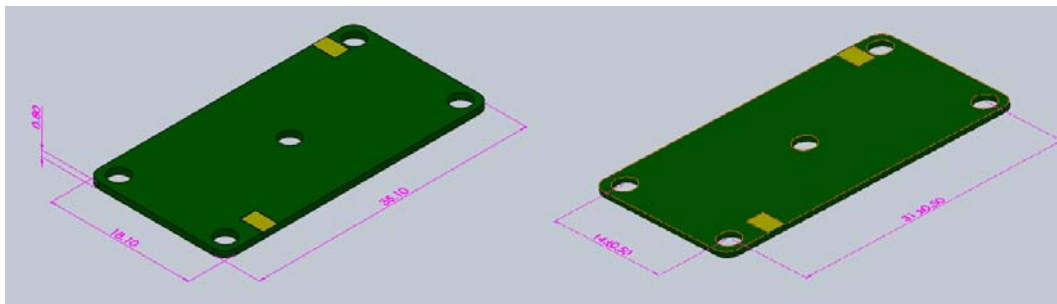

铝合金腔体螺孔示意图:

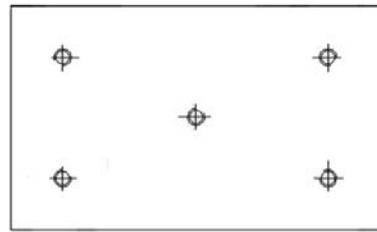
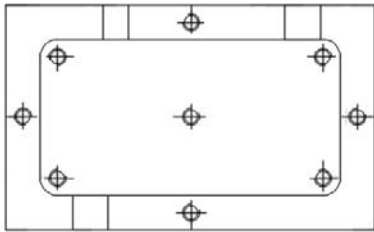

Sihid 矽海达科技  
Sihid Technology

深圳市矽海达科技有限公司

深圳市龙华新区民治大道 222 号东边商业大厦 608 室(邮编: 518131)

联系电话: 0755-23765232

Email: [sale@sihid.com](mailto:sale@sihid.com)

<http://www.sihid.com>